

M101P-ME, 10.1-inch Rugged Tablet PC

A Tablet Computer for Healthcare Professionals that Saves Time and Improves Efficiency

M101P-ME is a healthcare Windows-based tablet computer with a housing enhanced with antimicrobial properties, weighting at just 1200 grams (2.65 pounds). This mobile and portable device is flexible enough to function as a standalone device and competent enough to be used for all sorts of data collection, patient care, information management and wireless communication in Healthcare environments.

With rugged features, a crystal clear 1920 x 1200 resolution display, projected capacitive touch screen, barcode scanner and superior processing power coming from Intel's Apollo Lake processor, this tablet can be used in waiting rooms or nurse stations for communicating and documenting patient information, allowing paramedics and nurses to instantly access and keep patient records.



Highlights

- 10.1" 1920 x 1200 IPS LED Panel with direct optical bonding
- Intel® Apollo Lake Pentium N4200 processor
- Housing enhanced with antimicrobial properties
- Long battery life
- USB 3.0 (Type C) connector
- Optional 1D/2D barcode scanner to scan medications or wrist bands
- Lightweight, rugged, IP65 waterproof and dustproof
- IEC 60601-1, 60601-1-2 Healthcarely Certified

*Please consult your reseller or Winmate representative before purchasing.

*Accessories and Integrated Options may vary depending on your configuration. Visit Winmate website for more accessories and details.

M101P-ME 10.1-inch Rugged Tablet PC

A Tablet Computer for Healthcare Professionals that Saves Time and Improves Efficiency

Display Specification

Size	10.1-inch IPS display with LED Backlight
Resolution	1920 x 1200 WUXGA
Panel Brightness	600 nit
	With direct optical bonding for sunlight readable
Touch	Multi-touch projected capacitive
Contrast Ratio	800:1
Viewing Angle	85/85/85/85
Technology	<ul style="list-style-type: none">• Anti-glare technology• Ambient light sensor, e-compass, gyro, acceleration sensors• Automatic screen rotation• Intel HD Graphics (built-in CPU) video controller

System Specification

Processor	Intel Pentium N4200 Processor 1.10 GHz, up to 2.50 GHz with turbo boost technology
System Memory	4 GB LPDDR4(up to 8GB) ¹
Storage	128GB solid state drive (SSD) Optional up to 512GB, up to 128GB additional storage with micro SDXC card slot
Operating System	Windows 10 IoT Enterprise (64 bit)

Wireless Communication

WLAN	802.11 a/b/g/n/ac
Bluetooth	Bluetooth 5.0
GNSS	GPS, GLONASS
WWAN	Optional 4G LTE

Interface

Docking Connector	1 x 19-pin docking connector
HDMI	1 x Micro HDMI (Optional)
USB	1 x USB3.0 (Type A), 1 x USB3.0 (Type C) ²
Power Input	1 x Power Jack
Micro SD	1 x Micro SD Slot
Audio Connector	1 x Audio Combo connector (Mic in or Line Out)
Expansion Port	1 x Expansion Connector for USB 2.0 / Full RS232 (Optional)

Keyboard and Input

Touch	<ul style="list-style-type: none">• 10-point multi touch, support Rain, Glove, Stylus
Button	<ul style="list-style-type: none">• On-screen QWERTY keyboard• Button 1 x power, 1 x Home, 2 x volume key, 2 x function key (Programmable function key configured by Hottab Utility)
LED Indicators	Power, Battery, HDD, RF

Audio

Microphone	Built-in dual Digital Mic with Noise Cancellation
Speaker	2 x 1 watt speaker

Cameras

Web Camera	2MP webcam
Rear Camera	8MP rear camera with autofocus and LED light

Data Capture

Barcode	Optional 1D/2D Barcode Reader
HF RFID	Optional HF RFID reader 13.56 MHz

Security Function

Security	<ul style="list-style-type: none">• Password security for user and hard disk lock• Trusted Platform Module (TPM) 2.0• Kensington Lock
Mobile Device Mgmt.	SOTI Mobicontrol compatible ³

Regulatory Approvals

Certificate	<ul style="list-style-type: none">• CE, FCC, IC• IEC 60601-1, IEC 60601-1-2, EN 60601-1, ANSI/AAMI ES 60601-1
-------------	--

Mechanical and Environment

Dimension (W x L x H)	271.8 x 197.2 x 19 mm (10.7 x 7.76 x 0.75 inches) ⁴
Weight	1.2 kg (2.65 lbs) with standard battery, 1.4 kg (3.1 lbs) with optional high capacity battery
Housing	Rugged housing enhanced with antimicrobial properties
Operating Temperature	0°C to 35°C
Storage Temperature	-30°C to 70°C
Humidity	10% to 90% RH, non-condensing
IP Proof	IP65 certified, Dustproof and waterproof
Shock	MIL-STD-810G Method 516.6 Procedure I
Vibration	MIL-STD-810G Method 514.6 Procedure I
Drop	MIL-STD-810G Method 516.6, 4 ft to concrete ⁵

Power Management

Power Input	12-19V DC
Battery	7.4V, typ. 5140 mAh Li-Polymer Battery (2S1P) 7.4V, typ. 10280 mAh Li-Polymer Battery (2S2P, optional)
Battery Operating Time	Std. Battery: 8 hours ⁶
High Capacity Battery:	16 hours ⁶
Adapter	100-240V, 50-60Hz / 19V DC

Accessories

Standard Accessories

Adapter and Power Cord	922D072W19V1
Capacitive Stylus	9B0000000415
Standard Battery	98K000A00095

Optional Healthcarely Certified Accessories ⁷

Healthcare Grade Vehicle Dock	98DT00A00012
-------------------------------	--------------

Optional non-Healthcarely Certified Accessories ⁷

Desk Dock	98DT00A0000E
Vehicle Dock (without VGA output)	98K000A0003L
Battery Charger	98KT00A0000F
Smart Card Reader	98K000A0003U
Hand Strap	98K000A0003J
UHF RFID Reader	98K000A0004J
VESA Mount Kit	98KT00A0001H
Shoulder Strap	98K000A0003Q
Carry Bag	9B000000003J
Micro HDMI Cable	9491191190K1
Vehicle Charger	9226065W19V0
USB-C to Ethernet Adapter	9AN00000000I
USB-C to RS232 Adapter	9AN00000000L
USB-C to USB-A Hub	9AN00000000J

Drawing ⁸

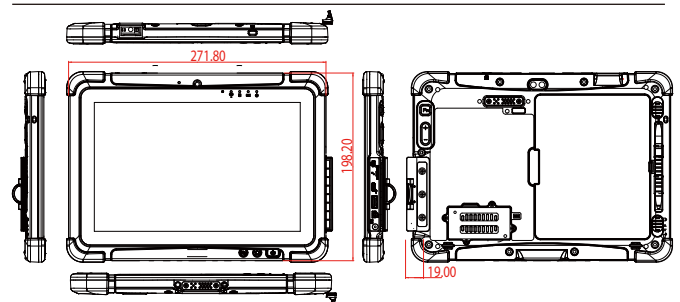

Caution

Do Not Expose the Battery Pack to Excessive Heat, or Extreme Heat (Near Fire, in Direct Sunlight for example)

Do not expose bare skin to this product when handling this unit in extreme hot or cold environments

1. Total usable memory will be less depending upon actual system configuration.
2. The USB Type-C connector follows USB 3.0 standard, which does not support Alternate Mode (ALT) or USB Power Delivery (USB-PD).
3. SOTI is available upon request.
4. Length measurements do not include protrusions. Weight varies with options and active pen.
5. The drop test with high-capacity battery must come with hand strap.
6. Measured at dimming LCD brightness. Varies depending on the usage conditions, or when an external device is attached."
7. Accessories and Integrated Options may vary depending on your configuration.
8. This is a simplified drawing and some components are not marked in detail.

